

2024-25



harmonium.design

HARMONIUM

Wall Panels
Ceiling Panels
Creations
Room Dividers
Workspace Dividers
Screens

PRODUCT CATALOGUE

06	Trends, Colours
08	Wall Panels
72	Ceiling Panels
88	Creations
96	Room Dividers
100	Workspace Dividers
106	Screens

harmonium.design



01	02	03	04	05	06	07	08	09	10	11	12	13	14	15	16	17	18	19	20
ONYX	RIVER	PUMICE	POLAR	CANARY	SAND	WAKAME	GLACIER	SAKURA	AMETHYST	DRAGON	ELEPHANT	IGUANA	CAMEL	STARFISH	CORAL	JADE	STORM	MACAW	PINECONE

TRENDS & COLOURS

BAUHAUS
Avant-Garde Tribute:

Immerse in timeless design with "Bauhaus," inspired by the movement's principles of simplicity and artistic expression. Each piece combines precise geometry with modern innovation, reflecting contemporary hues while paying homage to the Bauhaus tradition.

HOP
Help Our Planet:

HOP is an artistic plea for sustainability, blending creativity with environmental awareness. Each design sparks reflection on our relationship with nature, urging collective action for a healthier planet. It's not just a collection; it's a reminder of our responsibility to Earth's vitality.

PULSE
Youthful Energy:

Youth in Bloom: Bold colours and dynamic patterns celebrate youthful vitality.

CHILWE
Nature-Inspired Elegance:

Wood Kick: Fusing wood warmth with contemporary elegance for a stylish experience.

HARMONY
Emotional Intensity:

Heart Stop: Rich colours and exquisite details capture passionate elegance.

ESSENTIAL
Cosmic Exploration:

Star Gazer: Inviting you to explore the cosmos with futuristic textures and a cosmic palette. Fashion is our canvas for expressing present trends and anticipate the future with creativity and innovation in every detail.

BASICS

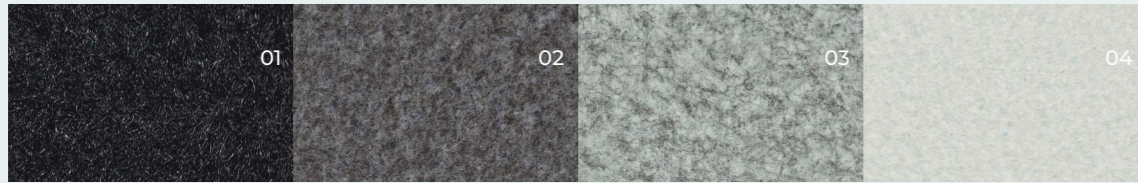

ONYX RIVER PUMICE POLAR

PULSE

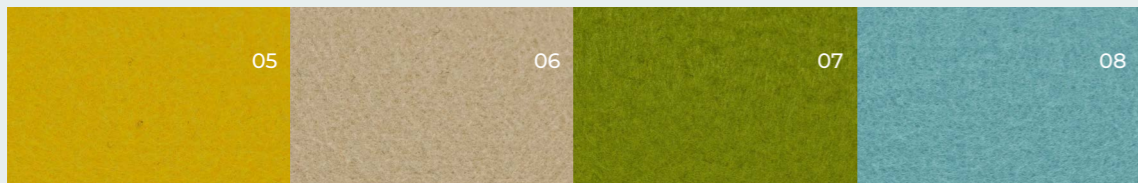

CANARY SAND WAKAME GLACIER

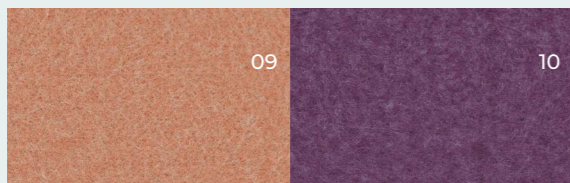

SAKURA AMETHYST

CHILWE



DRAGON ELEPHANT IGUANA CAMEL



STARFISH

HARMONY

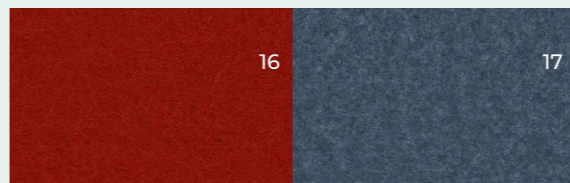

CORAL STORM

ESSENTIAL

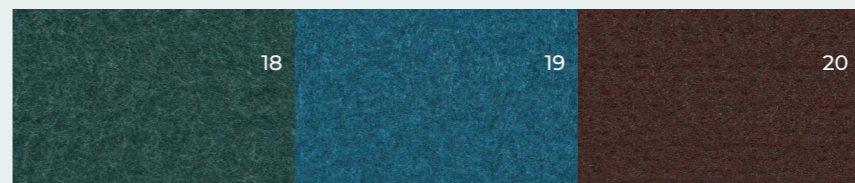

JADE MACAW PINECONE

WALL PANELS

PULSE

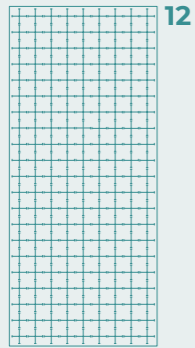

GEOMETRIC

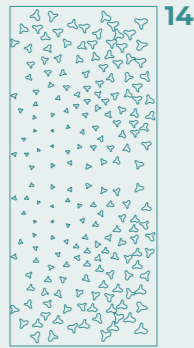

FREEDOM

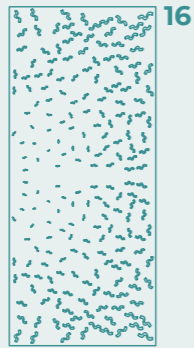

FRAGMENTS

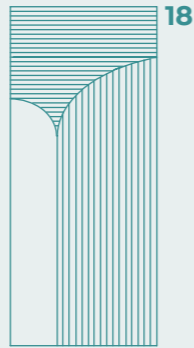

FLOW

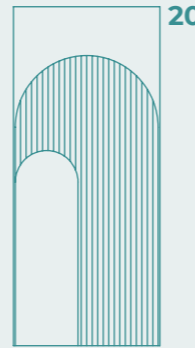

SINGULAR ARCH

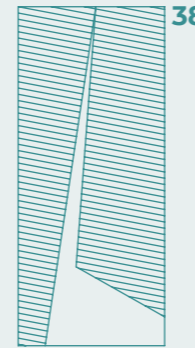

DISRUPTIVE

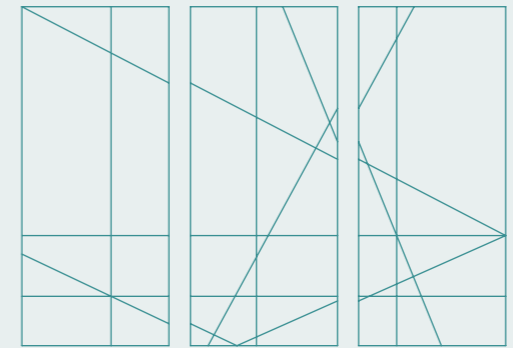

TRIBECA

ESSENTIAL

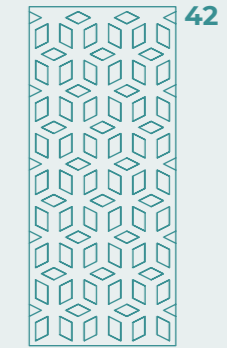

CUBE

CHILWE



CURL



HILLS

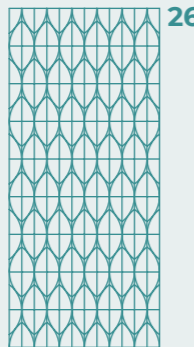

LAUREL



ROOTS

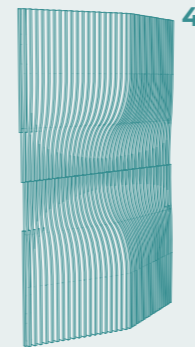

MORPH

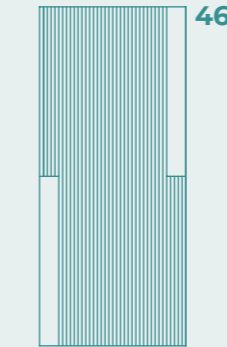

EXZENTRIC

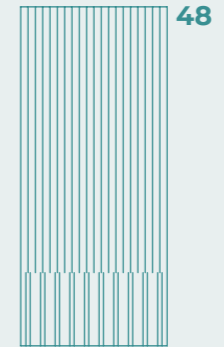

PLINTH

HARMONY

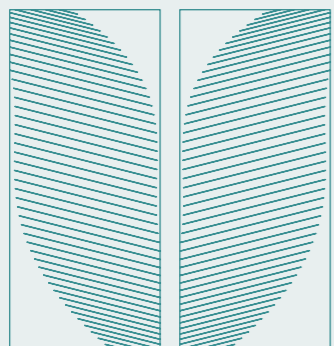

LEAF CORNER

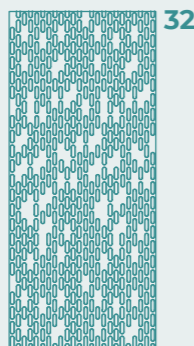

STEEL

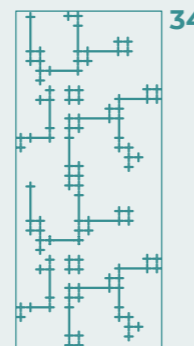

MAZE

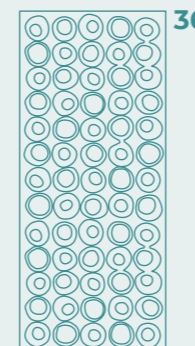

MOON PHASES

HOP



SUNRISE

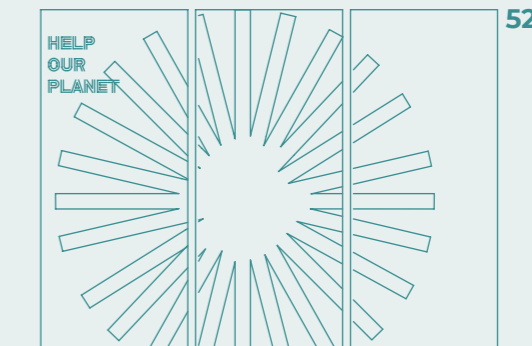

SUN

HOP

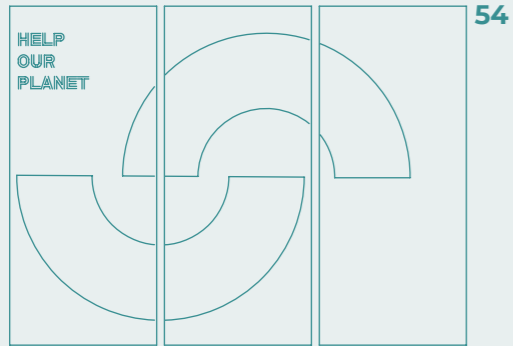

54

EQUATOR

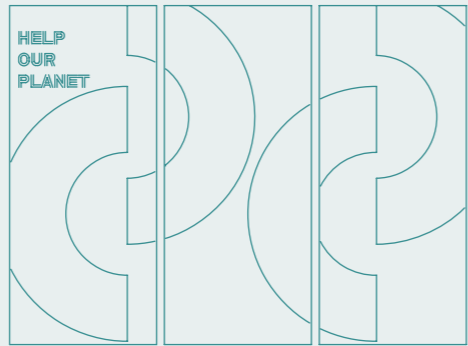

56

JET LAG



58

WAVES

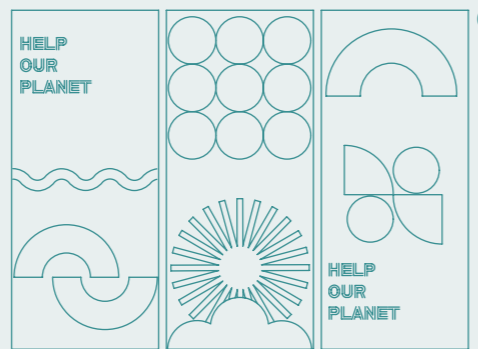

60

ANTROPHOCENE

BAUHAUS BY HARMONIUM

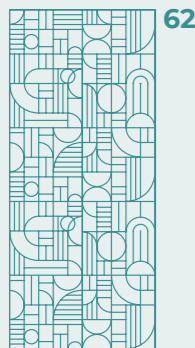

62

GEOMETRIC HARMONY

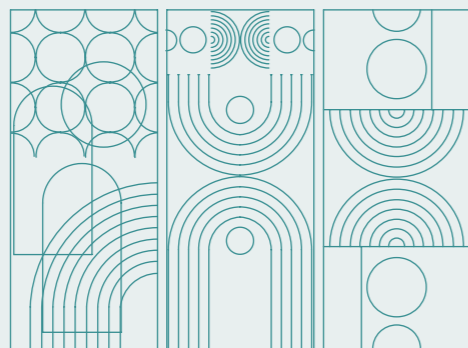

64

ABSTRACTION GAME

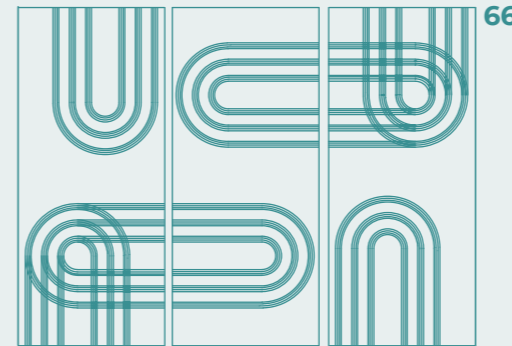

66

LIVING GEOMETRY

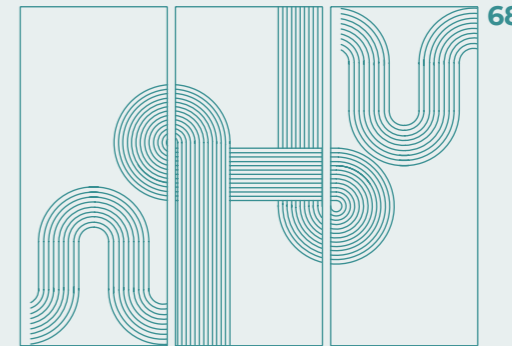

68

LINES IN MOTION

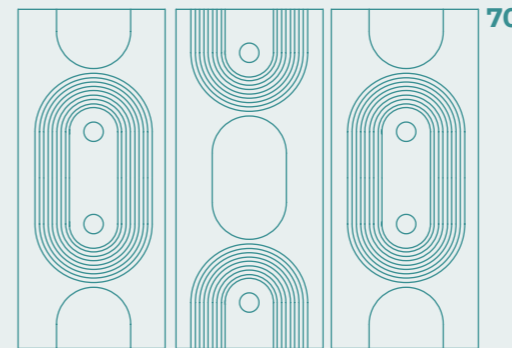

70

THE BAU LEGACY

GEOMETRIC

Designer
MOJA Design

Geometric is a timeless design with cubic shapes crafted together into a straightforward wall panel. It ensures stylish walls that blend perfectly into the background of your interior.



harmonium.design

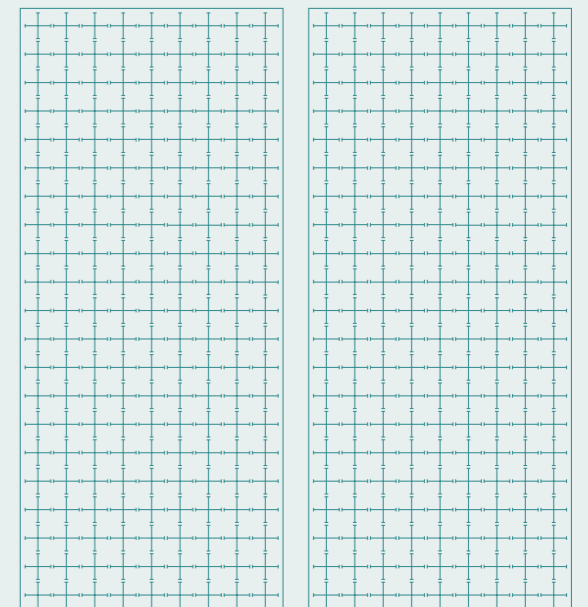

FREEDOM

Designer
MOJA Design

A fun display of shapes, creates curiosity and joy through its distribution density and size variation. The shapes abstractly fly towards the edges of the panel, lending the surrounding some lightness and playfulness.

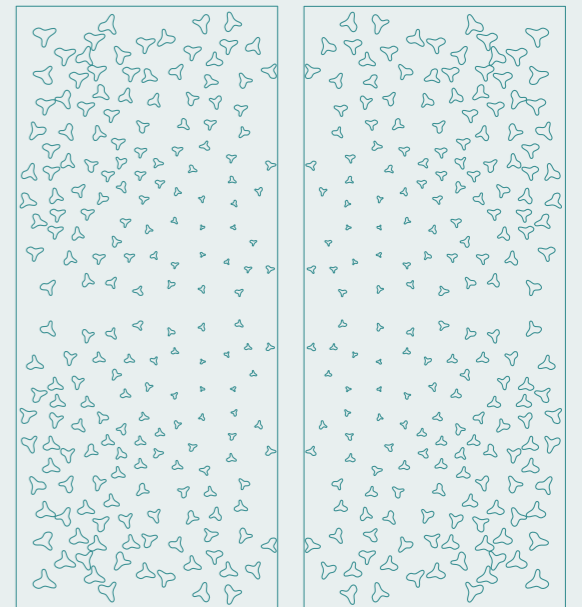

FRAGMENTS

Designer
MOJA Design

Lose yourself in this genuinely enticing pattern and discover how a seemingly simple shape can form a beautiful art piece in your office or home.

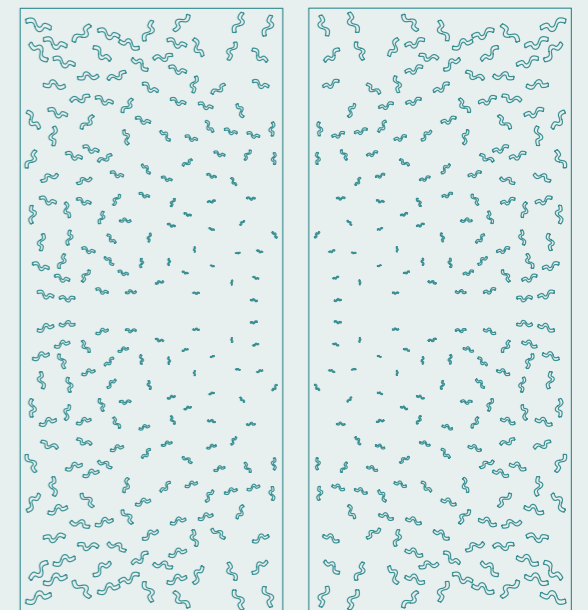

harmonium.design

FLOW

Designer
Nerea Orenes

The term Flow defines a comfortable but also elegant space here. In Flow, arch and line flow to create a fresh, contemporary rhythm. Colour adds subtleties, building a subtle, calmed space in the sand, pumice or iguana version, while with macaw, jade or amethyst, the background turns itself into the protagonist. Sakura creates a lively, fresh space.

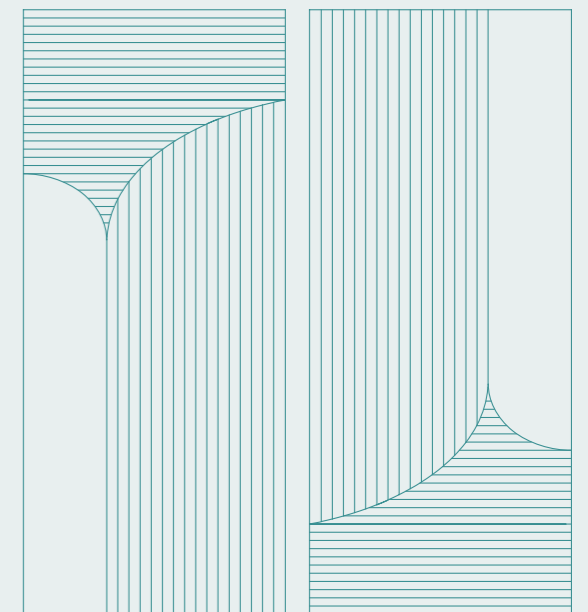

SINGULAR ARCH

Designer
Nerea Orenes

The repetition of the classic arch in its most slender and subtle form creates a contemporary and elegant background, where the acoustic panel is the protagonist of an extremely formal space in its Sand, Onyx, Iguana or Amethyst version while creating a comfy, lively space in Sakura or Canary.

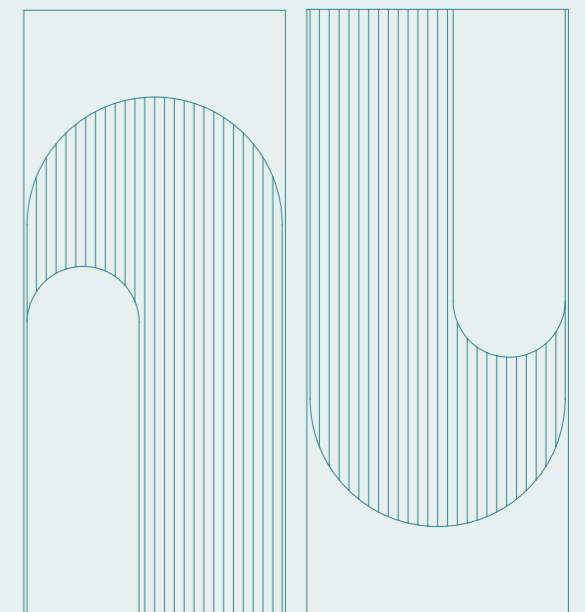

harmonium.design

CURL

Designer
Clara Sullà

Elevate your spaces with Curl, inspired by nature's captivating imprints. Multiply its design on your wall for dynamic elegance and undeniable acoustic comfort. Choose from a range of natural tones to enhance your surroundings, adding a touch of natural charm.

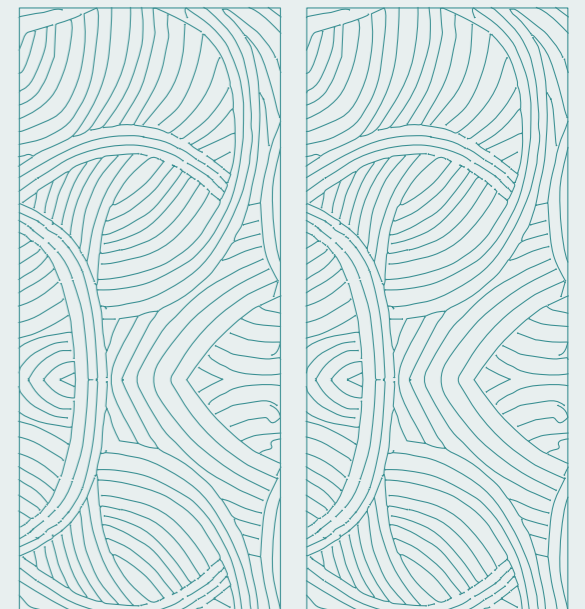

HILLS



Designer

Laura Junco Cañedo

A balanced design with curves arranged harmoniously along the panel, generating a pleasant rhythm as if they were mountains. Increase the acoustic comfort of your space by adding a decorative element to your walls.

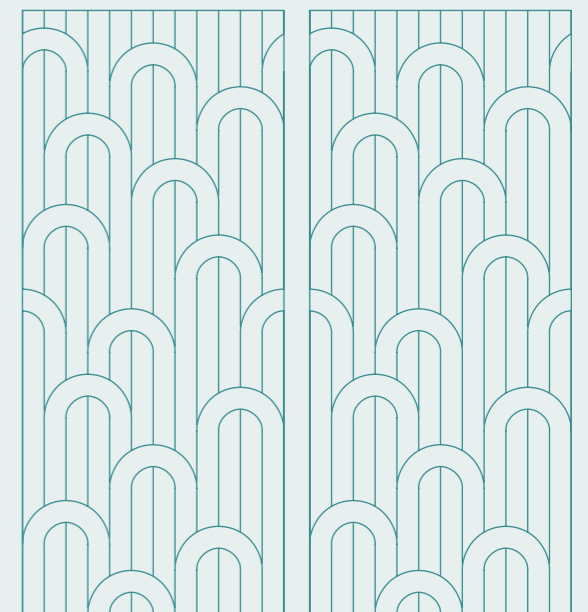

LAUREL

Designer

Laura Junco Cañedo

With its geometric shapes inspired by the Laurel tree, this design combined along a wall simulates a continuous wall of leaves. Thanks to its symmetry, it can be scaled in all directions to control the noise level of the space.

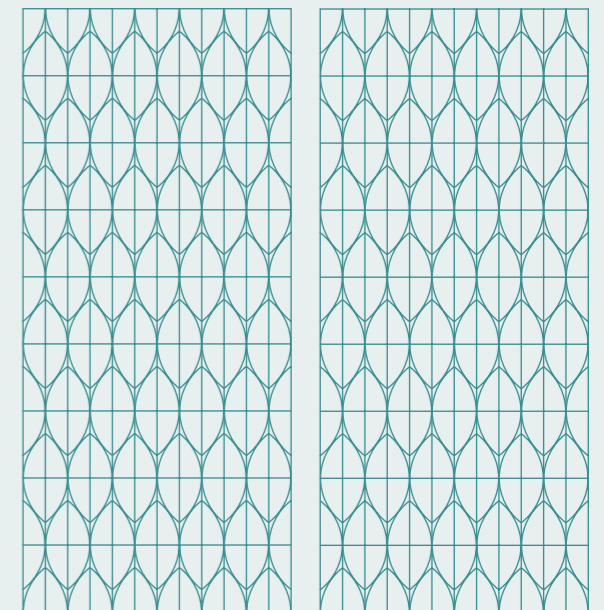

ROOTS



Designer

Laura Junco Cañedo

This elegant acoustic wall covering is inspired by the roots of a tree. Its design interweaves different strokes to create a harmonious rhythm that harmoniously descends along the panel.

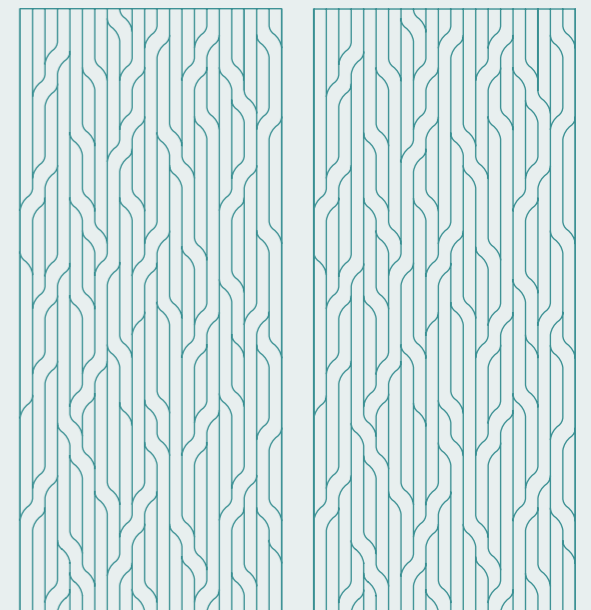

LEAF CORNER

Designer
MOJA Design

Let your walls do the talking and experience the fusion of floral flair and straightforward appeal in an impressive design piece. Leaf conjures up a floral and timeless pattern on your wall and will complement your interior perfectly.

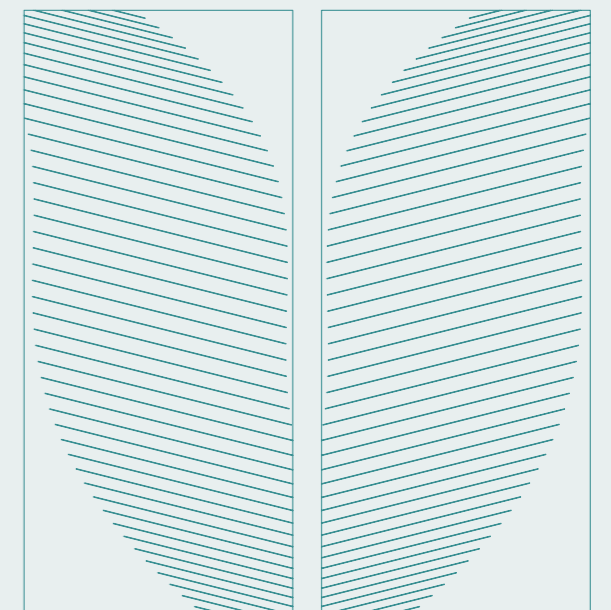

harmonium.design

STEEL



harmonium.design

Designer
MOJA Design

Steel was inspired by the precision of steel construction details. We designed a wall panel with a grid look: This appears straightforward, yet eccentric, the basic shapes guarantee a timeless look.

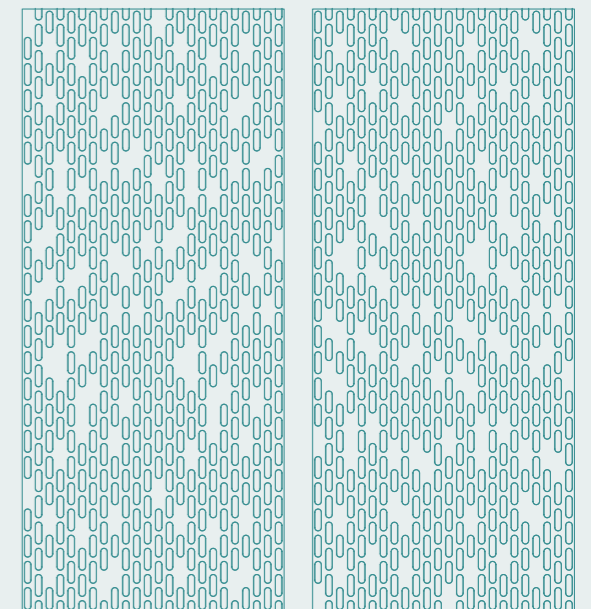

MAZE

harmonium.design



Designer
MOJA Design

Like a labyrinth, Maze is an eye-catcher. We used well-known basic shapes and combined them to create an unusual pattern. Maze is both an eccentric design piece and an inconspicuous background, it all depends on how Maze is staged.

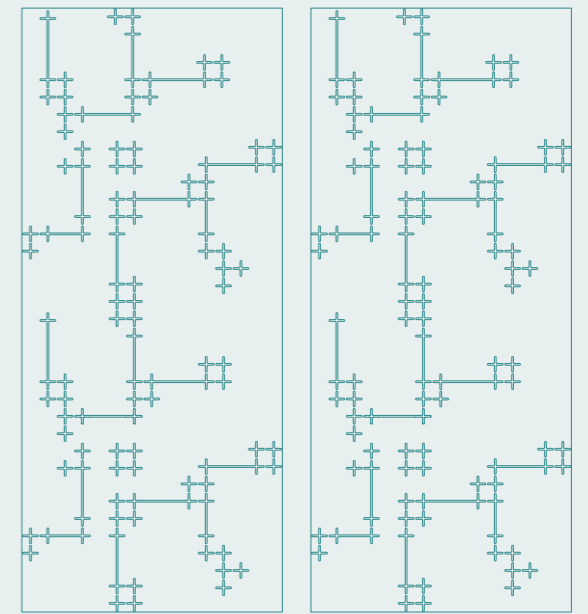

MOON PHASES

Designer
Clara Sullà

Indulge in serenity with Moon Phases inspired by rhythmic lunar cycles. Elevate interiors with timeless elegance and comfort. Choose from serene neutral colours, and consider multiplying the design for a touch of sophisticated personality.

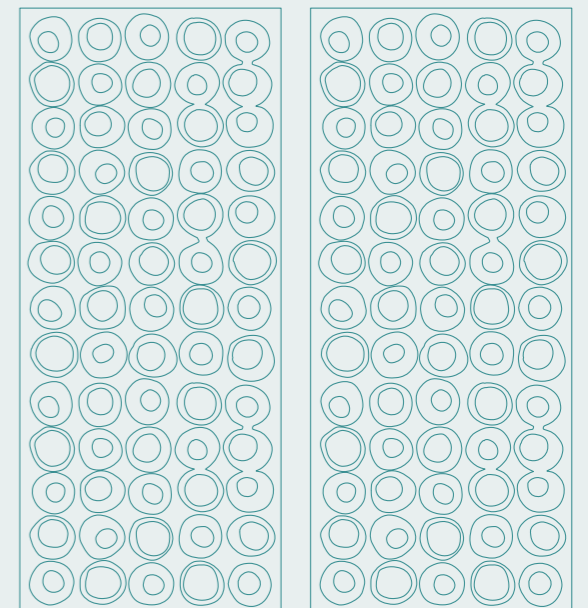

harmonium.design

DISRUPTIVE

Designer
Nerea Orenes

Geometry flows in Disruptive, creating a disruptive space with protagonist colours such as coral and amethyst, while providing dynamism to the space in a subtle and elegant way in the sand, pumice or iguana version.

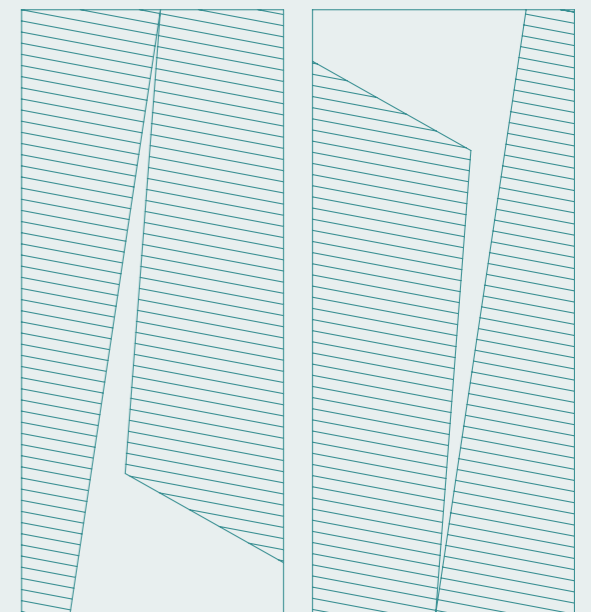

HARMONY COLLECTION

TRIBECA

Designer
Nerea Orenes

The series Tribeca creates a relaxed background for a dynamic space of delicate minimalism, whose versatile character allows to build very different spaces from very sophisticated till lively and casual.

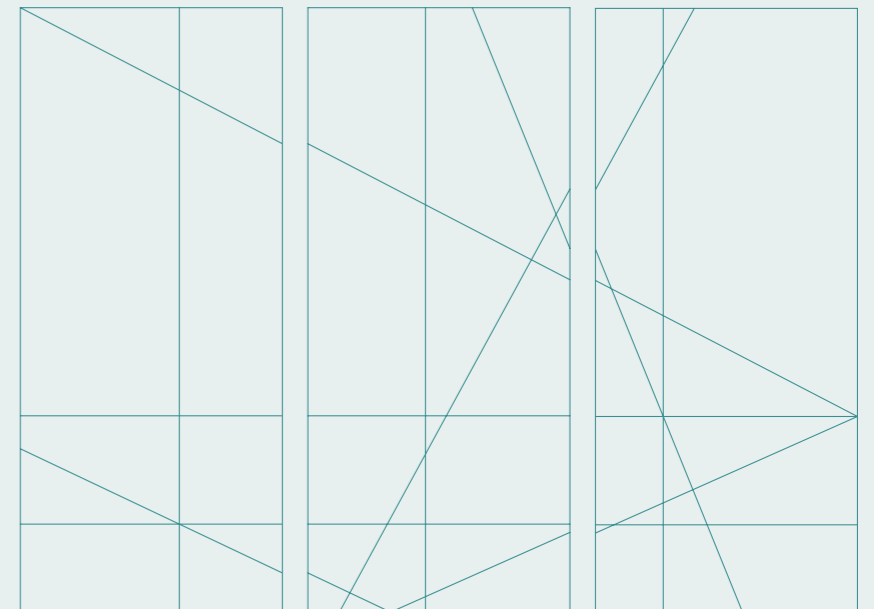

harmonium.design

CUBE

Designer

Laura Junco Cañedo

Like a deconstructed checkerboard, this geometric design has a three-dimensional character thanks to the cuts made in the panel. It subtly raises the tabs to generate new volumes that will give dynamism to the space.

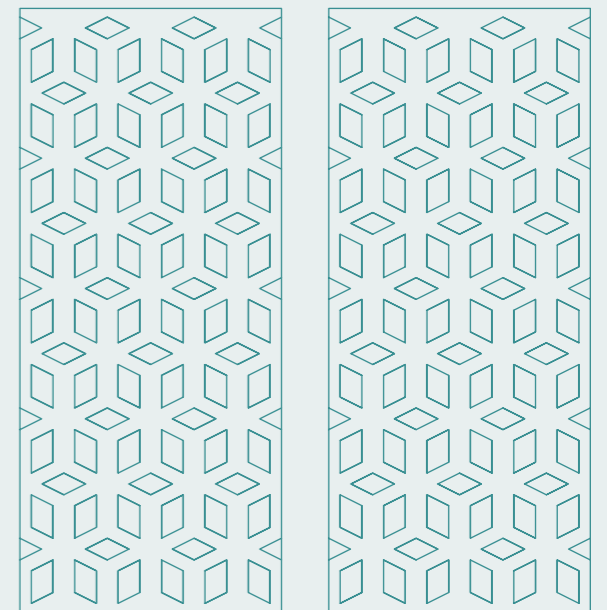

harmonium.design

ESSENTIAL COLLECTION

MORPH

Designer
MOJA Design

Many factors make Morph unique. The fins of the different panels blend into each other, creating a fascinating colour gradient. Thanks to its design, Morph is also seamlessly adjustable and adapts to the height of your room.

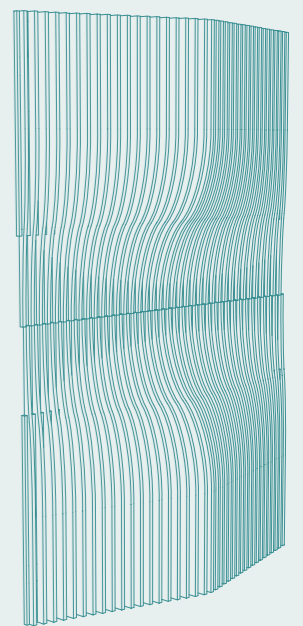

harmonium.design

EXZENTRIC

Designer
Nerea Orenes

The tranquil and elegant repetition of the line creates a structured space of contemporary geometry, to which further aspects are added on by colour. The magnetism of a minimalist painting is evoked in the Onyx version.

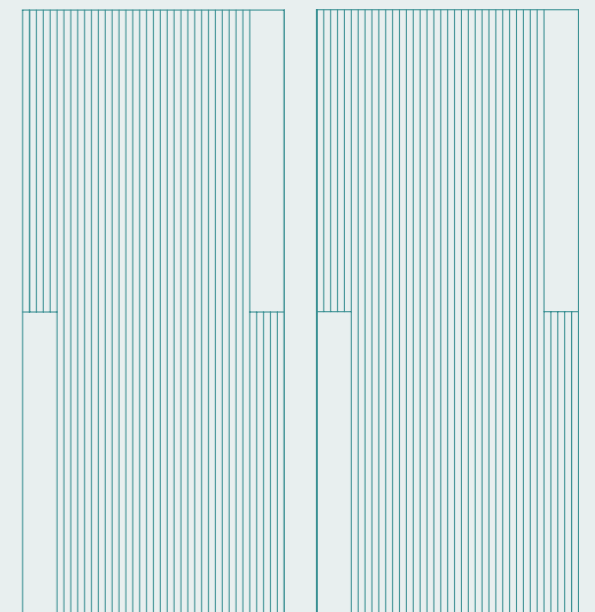

harmonium.design

ESSENTIAL COLLECTION

PLINTH

Designer
Nerea Orenes

This essential acoustic background is based on the classic abstraction of column and base, creating a tranquil background in its sand, camel or elephant version, while intense tones such as macaw emphasize rhythms, creating a very contemporary space.

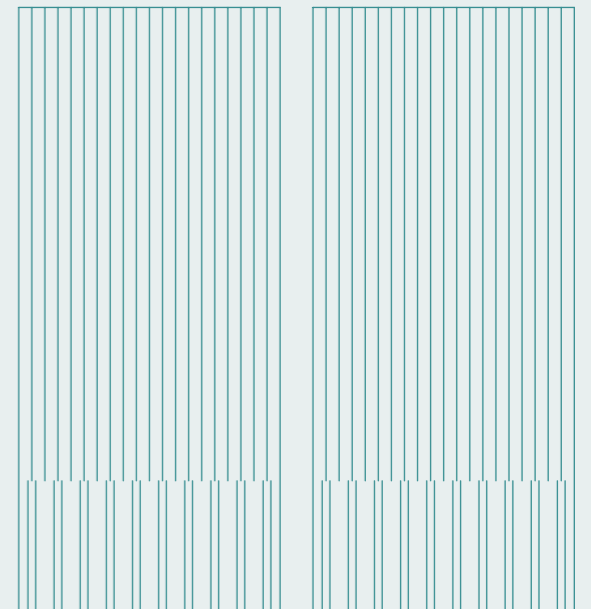

harmonium.design

SUNRISE

Designer
Elena Mas Parres

Dawn of Hope for Our Planet
In the golden glow of dawn, we find the promise of a new day for our beloved planet. The 'HELP OUR PLANET' concept comes to life in the SUNRISE design, where the sun's light becomes a beacon of hope for our planet. Becomes a beacon of hope and action.



SUN

harmonium.design



Designer
Elena Mas Parres

Rays of Change for Our Planet.
In the radiant essence of the 'SUN' design, we discover a brilliant metaphor to inspire action for our beloved planet. This concept, 'HELP OUR PLANET', manifests itself through the light and warmth of the sun. The sun's light and warmth represent global collaboration's positive energy and transformative power.

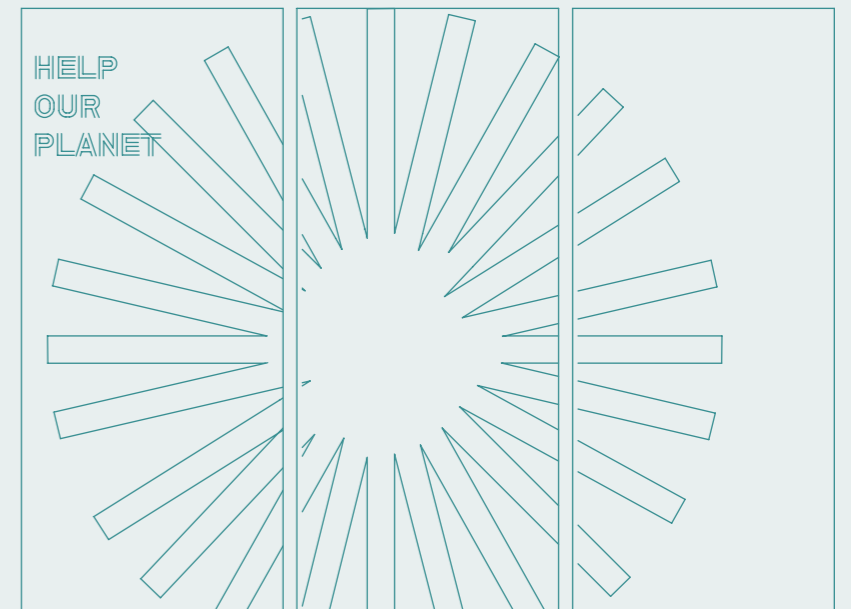

EQUATOR

Designer

Elena Mas Parres

A Design in Balance for Our Planet. At the heart of the 'HELP OUR PLANET' the concept of the EQUATOR design, an artistic expression that reflects the importance of balance and harmony in preserving our home. This design evokes the essence of the The equatorial line, a balance point on our planet, and invites us to embrace that balance. Planet invites us to adopt that balance in our daily actions.

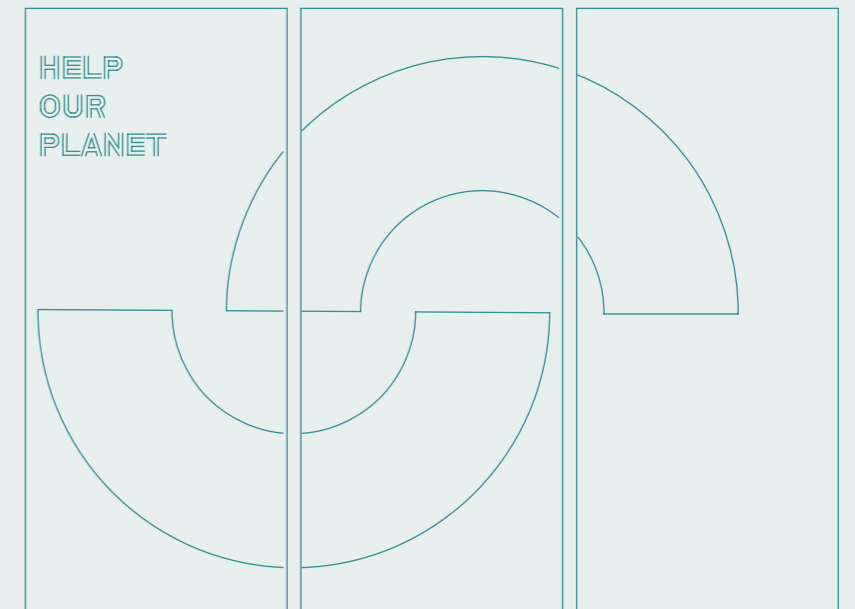

JET LAG

Designer
Elena Mas Parres

Conscious Awakening for the Planet
In the 'HELP OUR PLANET' concept, the JETLAG design emerges as a creative expression that invites us to think consciously.
Consciously awakening to the care of our shared home. Inspired by the notion of travel fatigue and the challenge of jetlag, JETLAG urges us to recognise the urgency of taking action to preserve our shared home. The urgency of taking action to safeguard the health of our planet.

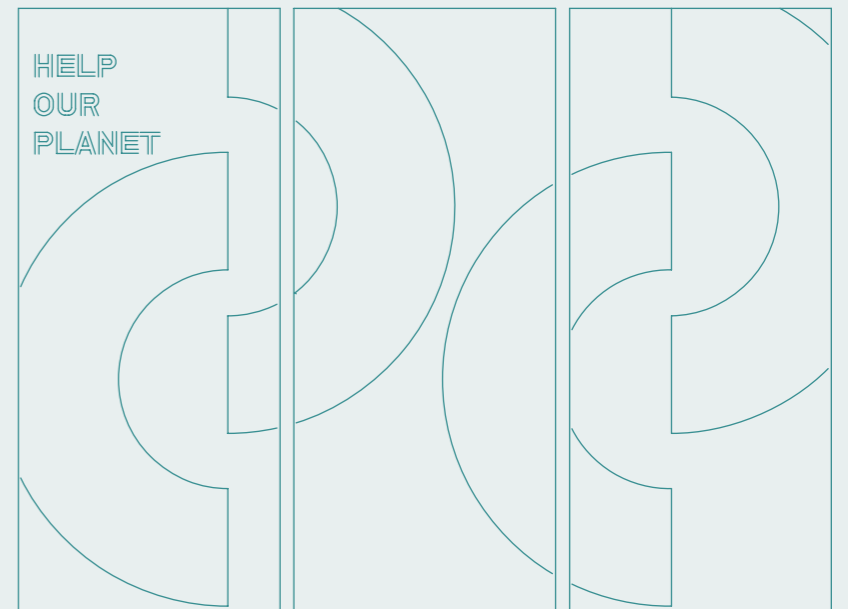

harmonium.design

WAVES

harmonium.design



Designer
Elena Mas Parres

At the heart of the 'HELP OUR PLANET' the concept emerges the WAVES design, an artistic expression that captures the dynamic and powerful essence of the tides, urging us to be the force of change for our planet. an expression that captures the dynamic and the powerful spirit of the tides, urging us to be the force of change expression that captures the dynamic and powerful spirit of the tides, urging us to be the force of change for the well-being of our planet. of change for the well-being of our planet. Inspired by the ceaseless energy

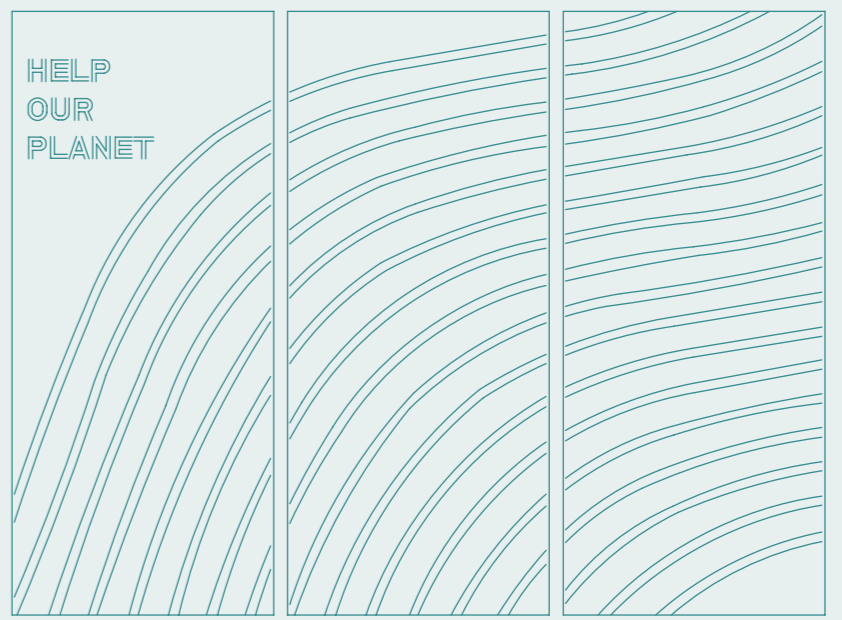

ANTROPHOCENE

Designer
Elena Mas Parres

Tides of Change for Our Planet
Designing a Sustainable Future.
At the crossroads of humanity and nature,
ANTORPHOCENE is born, a design reflecting
our relationship with our environment.
ReOects on our relationship with the
environment and the imperative need to
balance our actions for the benefit of our
planet. actions for the benefit of our planet.
Under the concept 'HELP OUR PLANET'

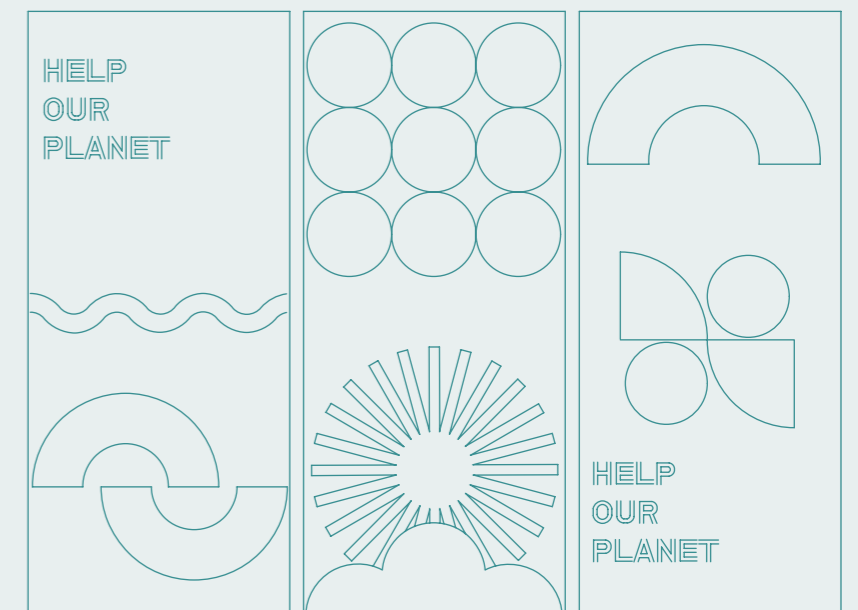

GEOMETRIC HARMONY

Designer

Laura Junco Cañedo

Inspired by the Bauhaus style, with its geometric shapes and abstract design, these are ideal for wall cladding. Create unique compositions that provide a differentiating aesthetic touch and help to control the noise level.



harmonium.design

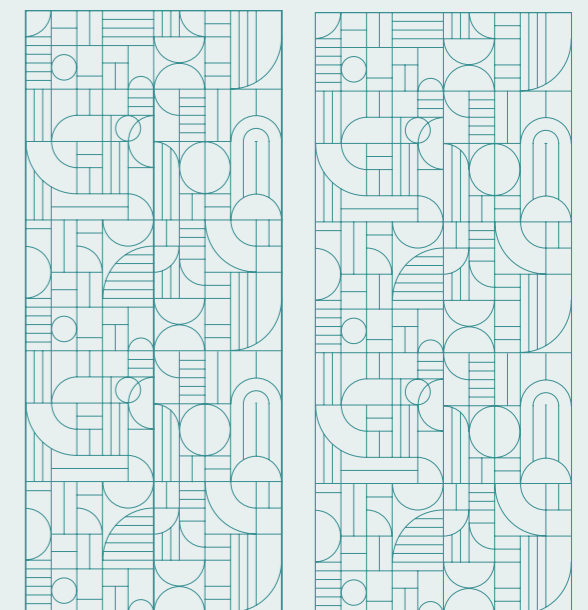

ABSTRACTION GAME

Designer

Elena Mas Parres

Straight lines and precise angles define the structure of "Abstraction Game". Inspired by the Bauhaus approach of eliminating the superfluous, the lines intertwine to form intriguing patterns, creating a visual experience that challenges the perception and provokes reflection. The symmetrical composition becomes the key to conveying a sense of order and proportion while carefully balanced asymmetries add a touch of dynamism and surprise.

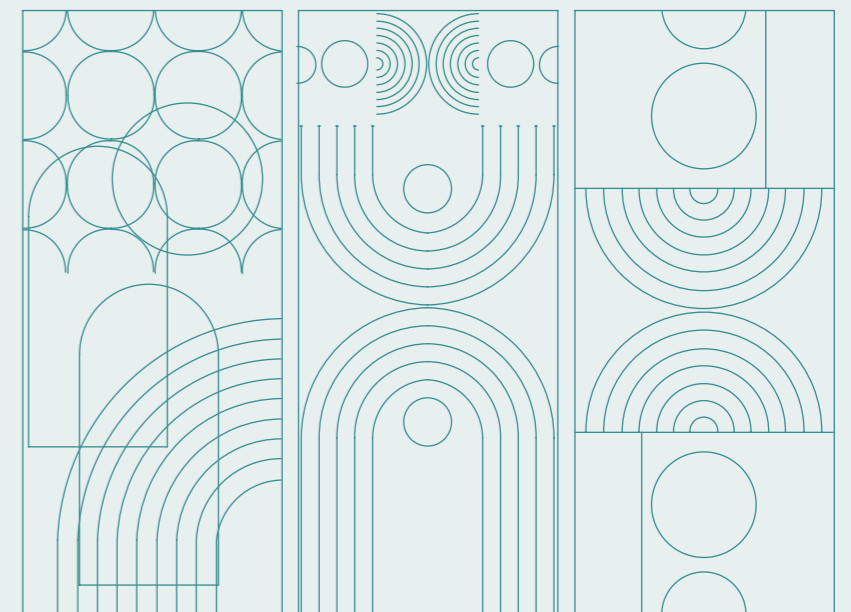

LIVING GEOMETRY

Designer

Elena Mas Parres

“Living Geometric” is a visual symphony in the fascinating design universe that pays homage to the iconic Bauhaus style. Homage to the iconic Bauhaus style. This design concept goes beyond aesthetics; it’s a statement of principles that celebrates the perfect fusion of geometric forms and functionality, transforming each element into a masterpiece of simplicity and harmony. Symmetry, a hallmark of the Bauhaus manifests itself in every corner of “Living Geometric” conveys a sense of order and balance that elevates aesthetics to new heights.

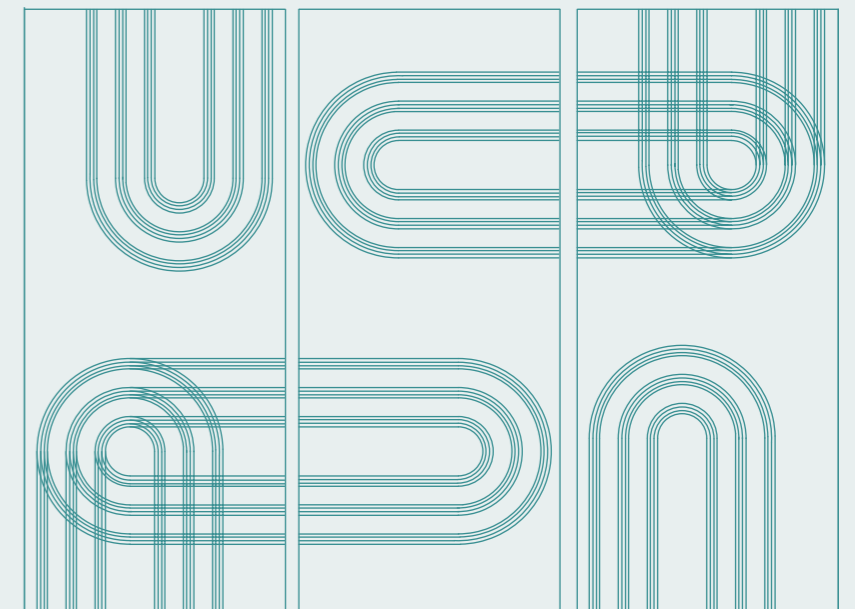

harmonium.design



LINES IN MOTION

Designer

Elena Mas Parres

In the intricate design scene, "Lines in Motion" is a living expression of the iconic Bauhaus style, carrying the essence of geometry in a visual ballet of lines. Iconic Bauhaus style carries the essence of geometry in a visual ballet of dynamic lines. Dynamic lines. This the design concept is a stylistic tribute and a celebration of the energy and vitality born from the interplay between precise shapes and movements. "Lines in Motion" is an extension of visual choreography in which lines in motion are aligned, becoming an integral stylistic part.

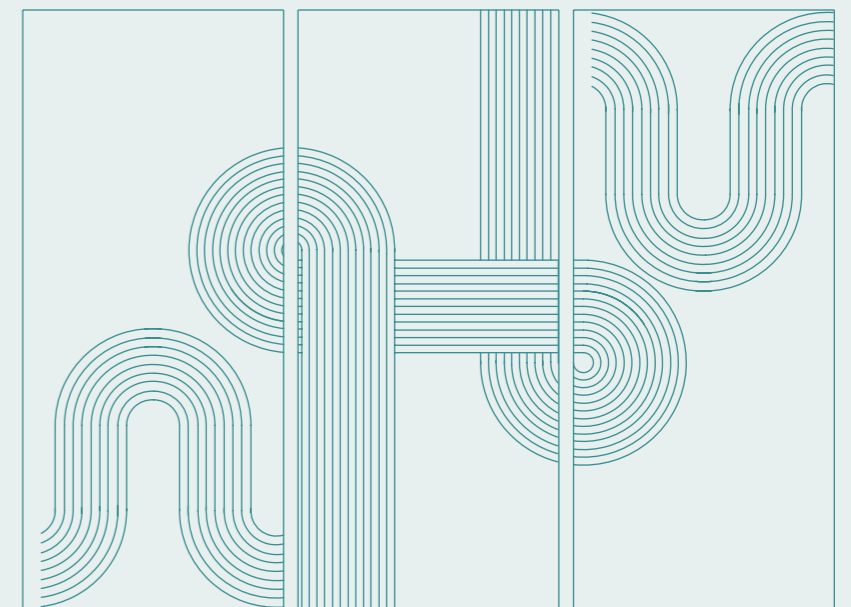

harmonium.design



THE BAU LEGACY

Designer

Elena Mas Parres

At the heart of contemporary design, "The Bau Legacy" emerges as a vibrant and respectful homage to the iconic Bauhaus movement. Respectful homage to the iconic Bauhaus movement. This project is an evocation of the timeless Bauhaus principles, taking them into the future with a fresh and contemporary interpretation. A fresh, contemporary interpretation. "The Bau Legacy seeks to inspire a new generation to embrace the Bauhaus legacy. Generation to embrace the Bauhaus legacy, taking it into the future with innovation, creativity, and a deep respect for its rich history. A deep respect for the rich history of design.

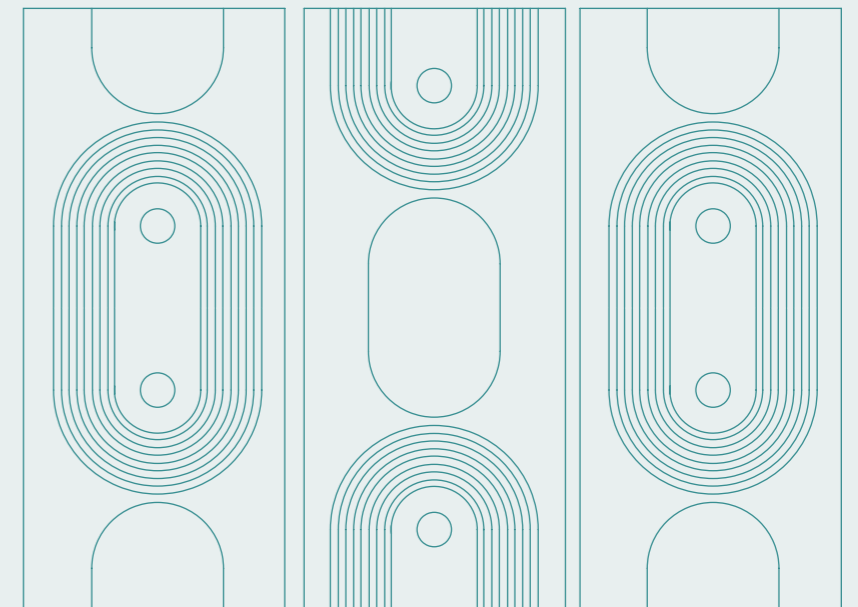

harmonium.design

CEILING PANELS

PULSE

74

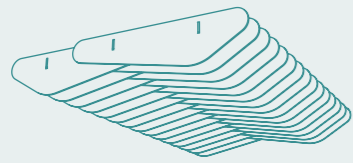

CHILWE

76

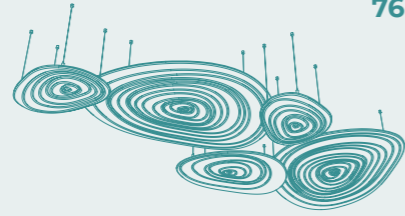

ESSENTIAL

86

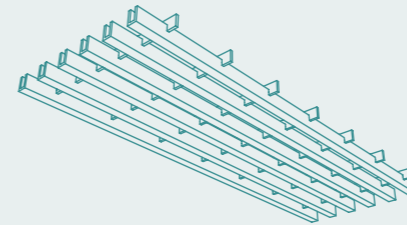

RESONANCE

78

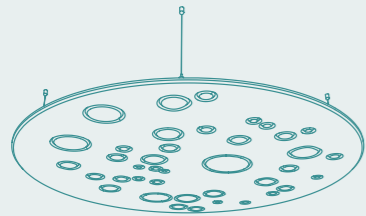

PEBBLE ISLAND

80



LUXINECO SYSTEM

MOON ISLAND

MONTSERA ISLAND

HARMONY

82

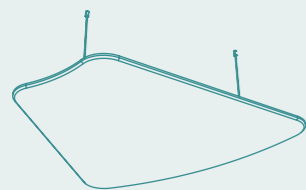

84



PETAL ISLAND S, L

BELLY

RESONANCE

Designer
Moja Design

Experience harmony from above with Resonance. With its two colours, Resonance blends in with any interior. You can create different variations when mounting it, thus creating your personal ceiling design.

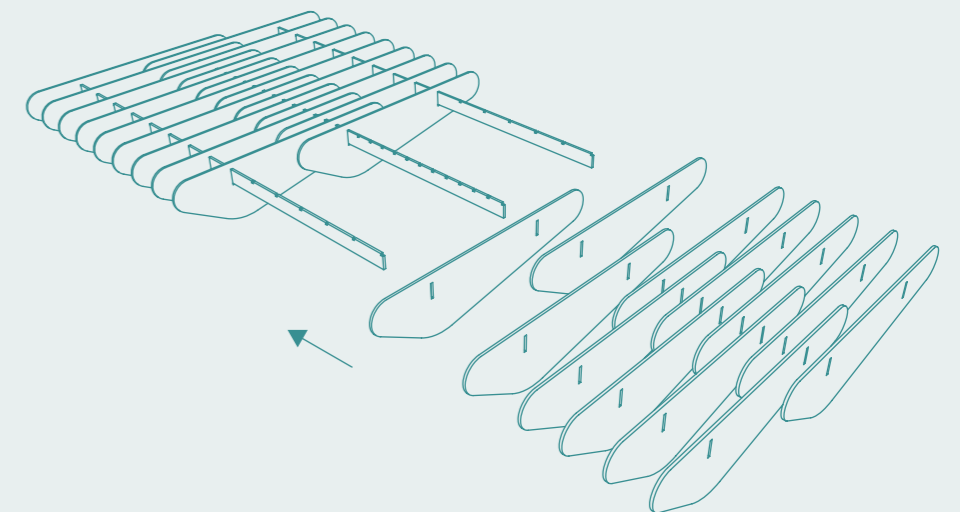

PEBBLE ISLAND

Designer
Clara Sullà

Elevate your space with the Pebbles acoustic element. Reminiscent of irregular round stones. It provides a versatile acoustic solution, whether suspended from the ceiling or mounted on the wall. Choose from various colours to craft personalized combinations, and watch as this distinctive design breathes personality and creativity into your surroundings.

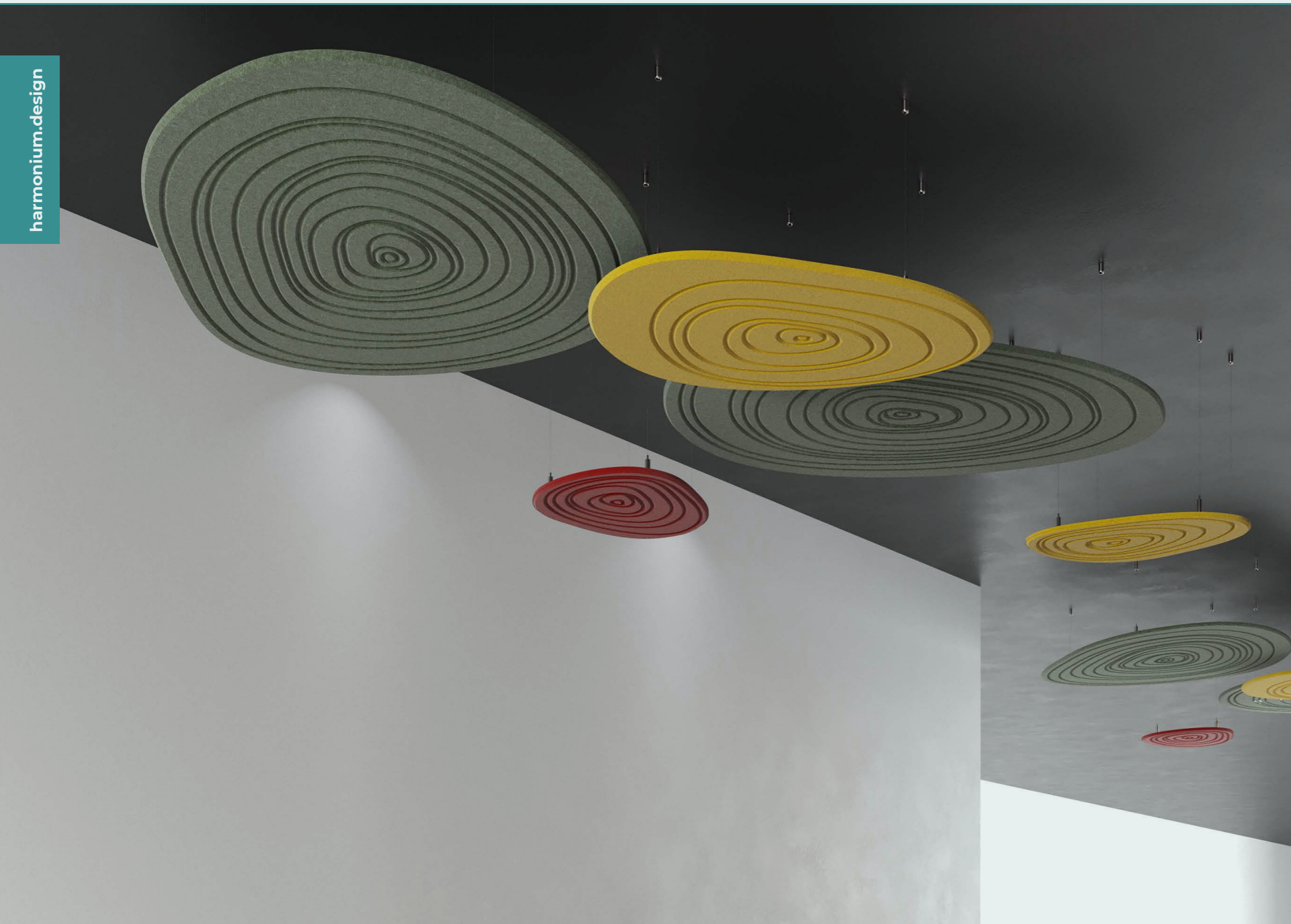
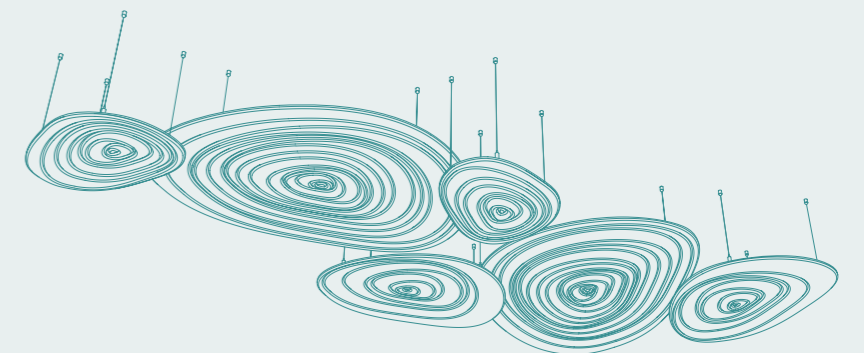

MOON ISLAND

Designer
Clara Sullà

Enhance your elegant and refined space with our Moon acoustic panel, inspired by the full moon's texture and cratered surface. Available in a white-ivory hue, it adds a touch of celestial beauty. Hang it from the ceiling or on the wall, providing an exceptional design for sophisticated interiors with a tasteful touch.

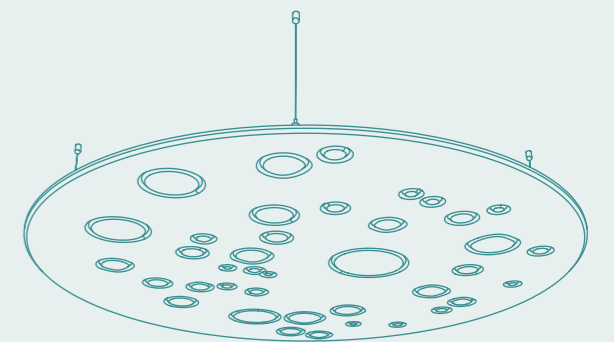

MONTSERA ISLAND

Designer
Clara Sullà

Transform your space with the creative and natural ambience of our Montsera acoustic panel. Hang it suspended from the ceiling or elegantly on the wall.
Play with different sizes and colours within the same space, allowing you to create a personalized and visually striking ambience.
Inspired by the iconic plant leaf, the "Montsera" the design exudes vibrant character.



PETAL ISLAND

Designer

Laura Junco Cañedo

Suspended island-type elements are perfect for optimising the space's acoustics while respecting the original ceiling design. With their rounded petal-shaped design, multiple compositions can be created at different heights.

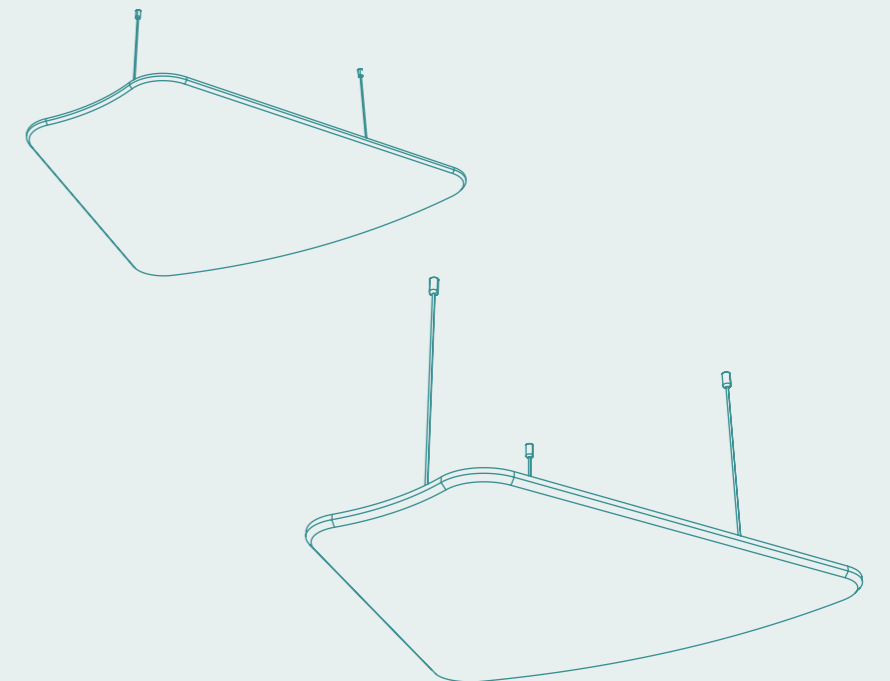

BELLY SYSTEM

Designer

Laura Junco Cañedo

The curved design of the Belly System makes it possible to create a continuous acoustic ceiling with organic shapes that mimic a 3D belly with different slat modulations. It is a self-supporting and scalable system that is easy to install in ceilings.

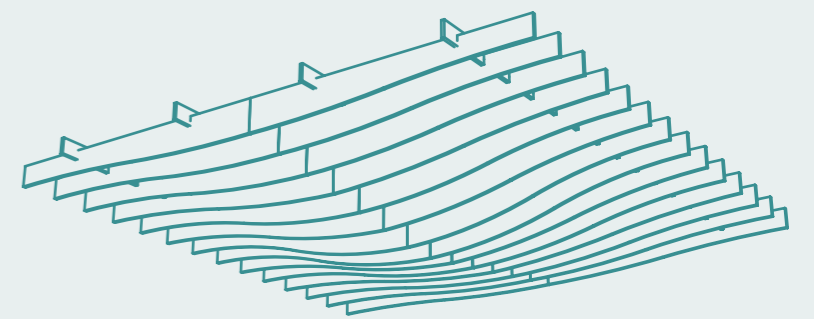

harmonium.design

LUXINECO SYSTEM

Designer

Laura Junco Cañedo

Luxineco is a modular acoustic ceiling system with an elegant design that provides continuity throughout the space, with different densities and slat heights. It is a self-supporting and scalable system that is easy to install in ceilings.

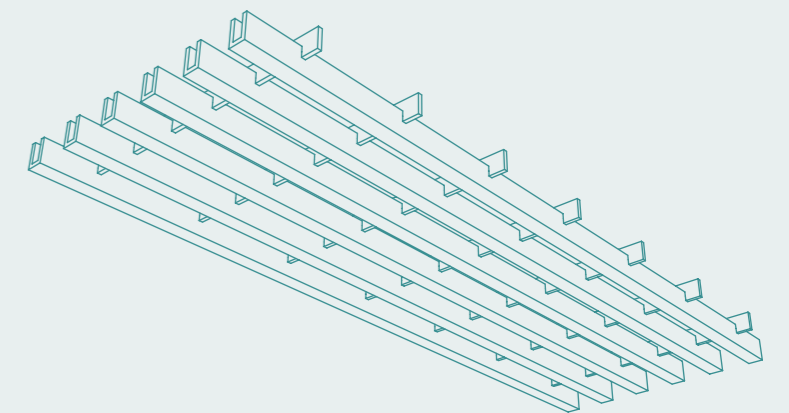

CREATIONS

PULSE

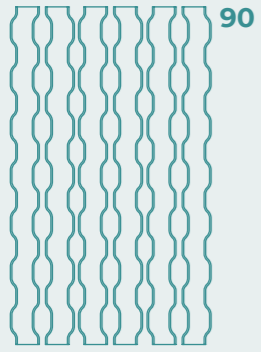

90

HEXAGON

CHILWE

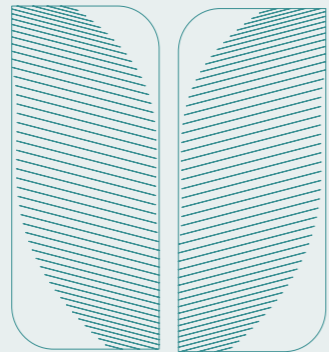

92

LEAF ROUNDED

ESSENCIAL

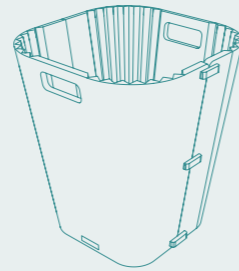

94

FLORA

HEXAGON

Designer
MOJA Design

Hexagon adds a futuristic touch to your room. The gaps between the panels create an aesthetic interplay with the see-through spaces of your wall. Hexagon consists of individual elements that allow you to create your unique arrangement.

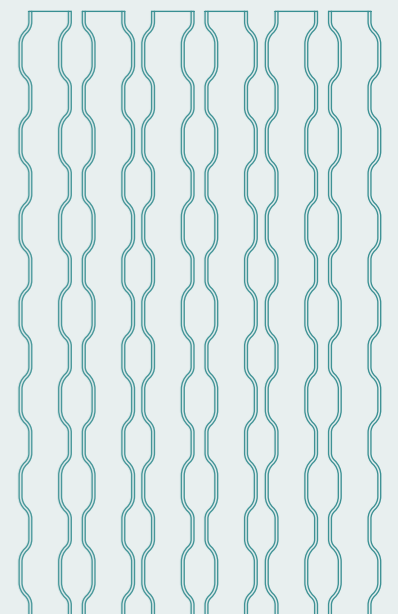

harmonium.design

LEAF ROUNDED

Designer
MOJA Design

Bring a touch of nature to your interior architecture. Leaf was made to mirror the calming shape and aura of lush leaves, which makes Leaf's Design appear timeless.

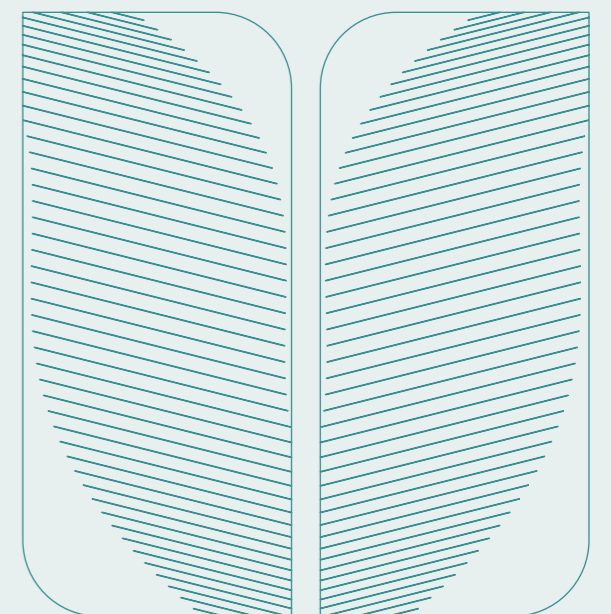

harmonium.design

ESSENCIAL COLLECTION

FLORA

Designer
MOJA Design

What's better than a flowerpot? A flower pot that absorbs echoes, of course. Meet Flora and give yourself, your employees, and their plants a flourishing working atmosphere.

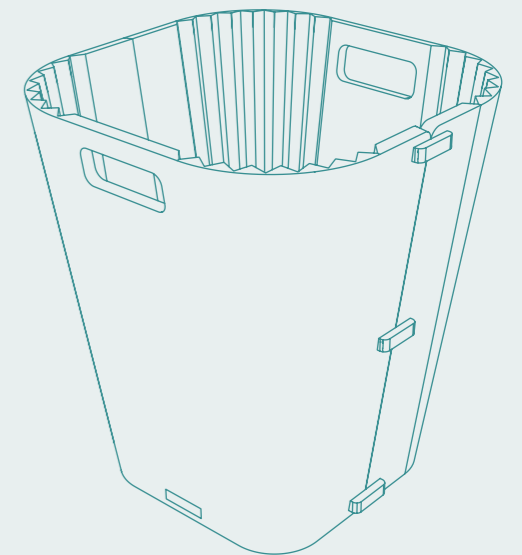

ROOM DIVIDERS

ESSENTIAL

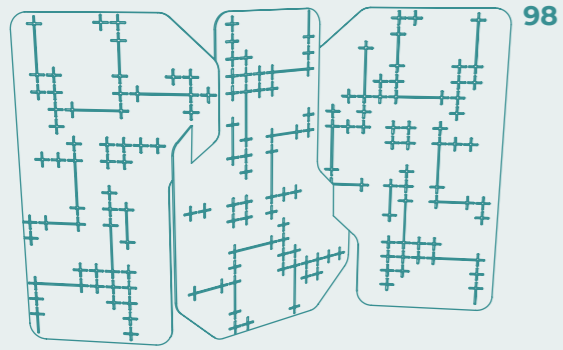

BERLIN

BERLIN

Designer
MOJA Design

Berlin is a simple and stylish solution for interestingly organizing your space. The panels are easy to connect and give you complete freedom to organize your space.

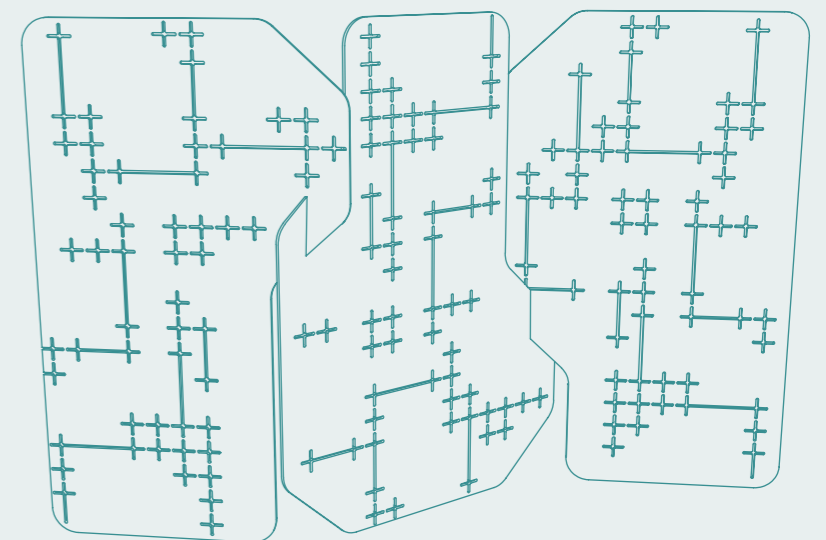

WORKSPACE DIVIDERS

PULSE

102

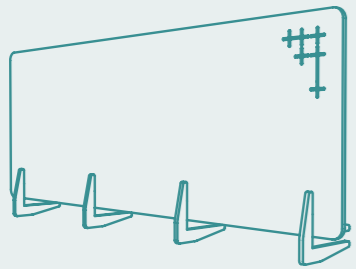

VAULT

ESSENTIAL

104

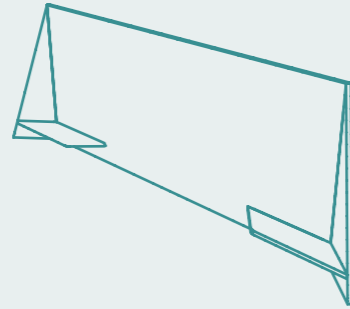

AEGIS

PULSE COLLECTION

VAULT

Designer
MOJA Design

This divider embodies the famous design principle "form follows function". The simplicity of its shape and assembly makes it essential and fits in every surrounding area.

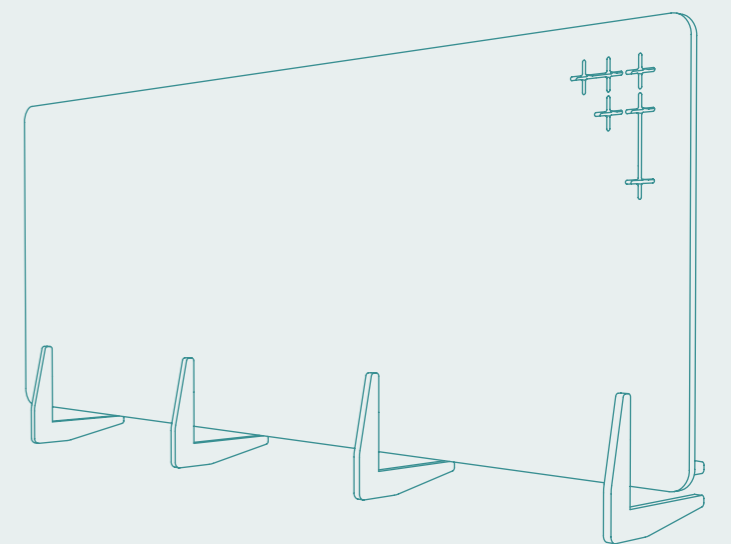

harmonium.design

AEGIS

Designer
MOJA Design

With its folded edges, this divider adds a subtle twist to its otherwise minimalistic design. It is also capable of supporting various small office appliances, making this panel your perfect assistant for concentrated work.

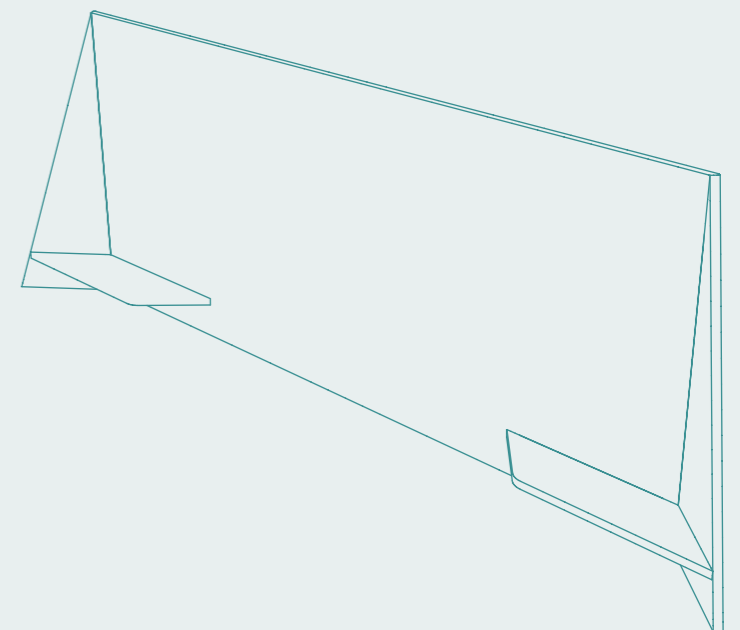

harmonium.design

SCREENS

HARMONY

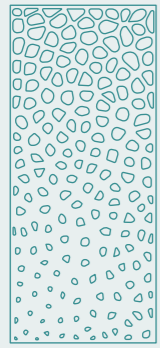

108

VORONOI

VORONOI

Designer
MOJA Design

Not unlike the cells in our bodies, all cells in this panel are dependent on each other. They seem to push and pull each other to evenly distribute across the surface, creating an organic collection of shapes.

